

COMPANY
WITH QUALITY SYSTEM
CERTIFIED BY DNV
ISO 9001

ET20F

3-PH. 2 POLE IP23

MECCALTE spa - Via Roma, 20 - 36051 CREAZZO (VI) ITALIA
Tel. 0444/396111 - Fax 0444/396166 - e-mail : mecc-alte-spa@meccalte.it
web site: www.meccalte.com

BRUSH + AVR

CHARACTERISTICS

POWER 230/400V AT 3000 RPM - 50 Hz

Type	CL. H ($\Delta T=125^{\circ}\text{C}$)			CL. F ($\Delta T=105^{\circ}\text{C}$)			STAND BY ($\Delta T=163^{\circ}\text{C}$)		CL. H ($\Delta T=125^{\circ}\text{C}$)		T.H.D.		
	THREE-PHASE		MOTOR STARTING CAPABILITY kVA	EFFICIENCY %			THREE-PHASE		AMBIENT TEMPERATURE 27°C			SINGLE-PHASE DELTA CONNECTION	
	KVA	KW COS φ 0,8		2/4	3/4	4/4	kVA	kW COS φ 0,8	kVA	kW COS φ 0,8		kVA COS φ 1	MOTOR STARTING CAPABILITY kVA
ET20FS-130/A	9	7,2	27	78,6	82,6	81,9	8,2	6,6	9,7	7,8	6	18	< 5
ET20FS-160/A	11,5	9,2	34	78,9	82,8	82,4	10,5	8,4	12,5	10	7,6	23	< 5
ET20F -200/A	13,5	10,8	40	79,4	83,5	82,9	12,2	9,8	14,2	11,4	9	27	< 5

POWER 277/480V AT 3600 RPM - 60 Hz

Type	CL. H ($\Delta T=125^{\circ}\text{C}$)			CL. F ($\Delta T=105^{\circ}\text{C}$)			STAND BY ($\Delta T=163^{\circ}\text{C}$)		CL. H ($\Delta T=125^{\circ}\text{C}$)		T.H.D.		
	THREE-PHASE		MOTOR STARTING CAPABILITY kVA	EFFICIENCY %			THREE-PHASE		AMBIENT TEMPERATURE 27°C			SINGLE-PHASE DELTA CONNECTION	
	KVA	KW COS φ 0,8		2/4	3/4	4/4	kVA	kW COS φ 0,8	kVA	kW COS φ 0,8		kVA COS φ 1	MOTOR STARTING CAPABILITY kVA
ET20FS-130/A	11	8,8	33	79,8	83,9	83,6	10	8	11,6	9,3	7,2	22	< 5
ET20FS-160/A	14	11,2	42	79,8	84,5	83,9	12,5	10	15	12	9,1	28	< 5
ET20F -200/A	16,5	13,2	50	80,5	84,6	84,1	14,5	11,6	17	13,6	10,8	33	< 5

Type	J (Kgm ²)		Weight (Kg)			Air Volume (m ³ /min)		Noise dB(A)			
	B3/B14	B3/B9	B3/B14	B3/B9	MD35	50 Hz	60 Hz	50 Hz		60 Hz	
								7m	1m	7m	1m
ET20FS-130/A	0,0241	0,0231	45,2	44,2	48,2	4,7	5,7	81	63	83	65
ET20FS-160/A	0,0288	0,0277	52,2	51,2	55,2	4,7	5,7	81	63	83	65
ET20F -200/A	0,0335	0,0323	60	59	63	4,7	5,7	81	63	83	65

TYPICAL ELECTRICAL DATA

Type		ET20FS-130/A	ET20FS-160/A	ET20F-200/A
Rating "H" class	kVA 50 Hz	9	11,5	13,5
Direct - axis synchronous reactance	X _d %	353	334	270
Direct - axis transient reactance	X' _d %	39,2	37,4	31,9
Direct - axis subtransient reactance	X'' _d %	22,4	21,2	18,6
Quadrature - axis synchronous reactance	X _q %	109,3	100,9	88
Quadrature - axis transient reactance	X' _q %	109,3	100,9	88
Quadrature-axis subtransient reactance	X'' _q %	44,3	42,6	39
Negative - sequence reactance	X ₂ %	24	22,4	18
Zero sequence reactance	X ₀ %	8,8	8,4	6,9
Transient time constant	T' _d (ms)	54	51	43
Subtransient time constant	T'' _d (ms)	11	10	9
Armature time constant	T _α (ms)	6	7,5	9
Open circuit time constant	T' _{do} (s)	0,65	0,58	0,5
Short - circuit ratio	K _{cc}	0,58	0,51	0,56
Stator winding resistance	Ω	0,712	0,569	0,425

ELECTRONIC REGULATOR ASR	PARALLEL DEVICE	THERMAL PROTECTION			HEATERS	MECHANICAL PROTECTION		
		PTC	BIMET DEVICE	PT100		IP21	IP23	IP45
●		<input type="checkbox"/>	<input type="checkbox"/>	<input type="checkbox"/>	<input type="checkbox"/>	●	<input type="checkbox"/>	

● = Standard

= Optional



OVERALL SIZE, STANDARD TYPE

dimensions in mm

FORM B3/B14

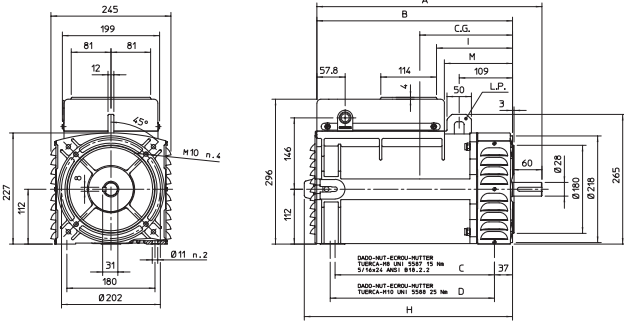

TYPE	A	B	C	D	H	I	M	L.P.
ET20F	460	400	325,5	335,5	425,5	155	139	YES
ET20FS	420	360	285,5	295,5	385,5	115	99	NO

FORM B9/c30

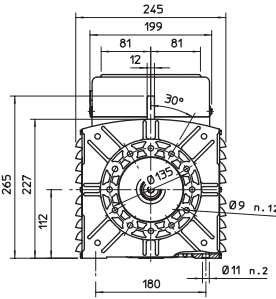

TYPE	B	C	D	H	I	M	L.P.
ET20	400	325,5	335,5	425,5	155	139	YES
ET20FS	360	285,5	295,5	385,5	115	99	NO

FORM MD35

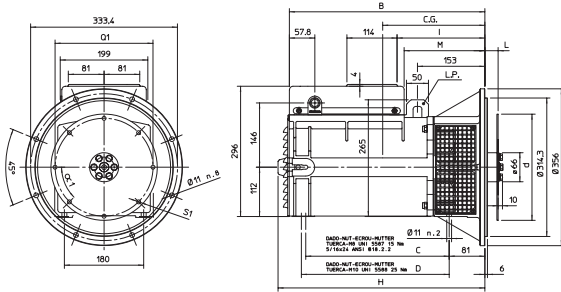

TYPE	B	C	D	H	I	M	L.P.
ET20F	444	325,5	335,5	469,5	199	183	YES
ET20FS	404	285,5	295,5	429,5	159	143	NO

SAE N.	GIUNTI A DISCO - DISC COUPLING - ACC. DISQUE					
	L	d	Q1	n. fori	S1	a1
6 1/2	30,2	215,9	200	6	9	60°
7 1/2	30,2	241,3	222,25	8	9	45°

GRAVITY/CENTER CG		
FORM	ET20FS	ET20F
MD35	246	239
B3/B14	210	203

FORM J609b

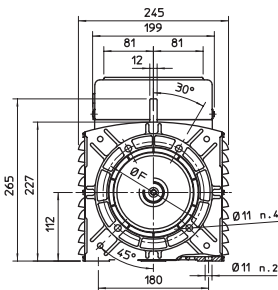

GRAVITY/CENTER CG		
FORM	ET20FS	ET20F
J609b	212	205
B9/c30	212	205

FORM	E	F	G
J609b	ø146	ø165	ø192
	ø163,6	ø196,85	ø216
	ø177,8		

OVERALL SIZE WITH ELECTRIC PANELBOARD TYPE

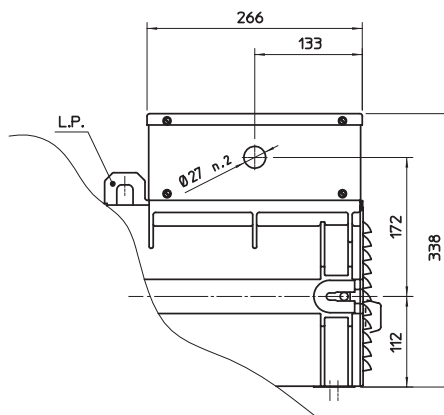

TYPE	L.P.
ET20F	YES
ET20FS	NO

