

05/09



COMPANY WITH QUALITY SYSTEM CERTIFIED BY DNV ISO 9001

ET16F

MECCALTE spa - Via Roma, 20 - 36051 CREAZZO (VI) ITALIA
 Tel. 0444/396111 - Fax 0444/396166 - e-mail : mecc-alte-spa@meccalte.it
 web site: www.meccalte.com

3-PH. 2 POLE IP23

BRUSH + AVR

CHARACTERISTICS

POWER 230/400V AT 3000 RPM - 50 Hz														
Type	CL. H (ΔT=125°C)						CL. F (ΔT=105°C)			STAND BY (ΔT=163°C)		CL. H (ΔT=125°C)		T.H.D. %
	THREE-PHASE		MOTOR STARTING CAPABILITY kVA	EFFICIENCY %			THREE-PHASE		AMBIENT TEMPERATURE 27°C		SINGLE-PHASE DELTA CONNECTION			
	kVA	KW COS φ 0,8		2/4	3/4	4/4	kVA	kW COS φ 0,8	kVA	kW COS φ 0,8	kVA COS φ 1	MOTOR STARTING CAPABILITY kVA		
ET16F-130/A	5,5	4,4	16,5	76,1	80,4	80,2	5	4	5,8	4,6	3,6	11	< 5	
ET16F-160/A	6,5	5,2	19,5	78,5	82,7	82,3	5,8	4,6	7	5,6	4,3	13	< 5	

POWER 277/480V AT 3600 RPM - 60 Hz														
Type	CL. H (ΔT=125°C)						CL. F (ΔT=105°C)			STAND BY (ΔT=163°C)		CL. H (ΔT=125°C)		T.H.D. %
	THREE-PHASE		MOTOR STARTING CAPABILITY kVA	EFFICIENCY %			THREE-PHASE		AMBIENT TEMPERATURE 27°C		SINGLE-PHASE DELTA CONNECTION			
	kVA	KW COS φ 0,8		2/4	3/4	4/4	kVA	kW COS φ 0,8	kVA	kW COS φ 0,8	kVA COS φ 1	MOTOR STARTING CAPABILITY kVA		
ET16F-130/A	6,6	5,3	20	76,5	80,8	80,6	6	4,8	7	5,6	4,3	13	< 5	
ET16F-160/A	7,8	6,2	24	78,5	82,8	82,5	7	5,6	8,4	6,7	5,2	16	< 5	

Type	J (Kgm ²)	Weight (Kg)	Air Volume (m ³ /min)		Noise dB(A)			
					50 Hz		60 Hz	
			50 Hz	60 Hz	7m	1m	7m	1m
ET16F-130/A	0,0129	30	3,4	4,3	60	78	62	80
ET16F-160/A	0,0156	34	3,4	4,3	60	78	62	80

TYPICAL ELECTRICAL DATA

Type		ET16F-130/A	ET16F-160/A
Rating "H" class	kVA 50 Hz	5,5	6,5
Direct - axis synchronous reactance	X _d %	303	249
Direct - axis transient reactance	X' _d %	40,8	38,1
Direct - axis subtransient reactance	X'' _d %	20	18,6
Quadrature - axis synchronous reactance	X _q %	100	96,2
Quadrature- axis transient reactance	X' _q %	100	96,2
Quadrature-axis subtransient reactance	X'' _q %	37,2	35,5
Negative - sequence reactance	X ₂ %	21,6	18,6
Zero sequence reactance	X ₀ %	8,2	7,1
Transient time constant	T' _d (ms)	41	38
Subtransient time constant	T'' _d (ms)	10	9
Armature time constant	T _α (ms)	5	6
Open circuit time constant	T' _{do} (s)	0,8	0,9
Short - circuit ratio	K _{cc}	0,82	0,85
Stator winding resistance	Ω	1,5	1,15

ELECTRONIC REGULATOR ASR	PARALLEL DEVICE	THERMAL PROTECTION			HEATERS	MECHANICAL PROTECTION		
		PTC	BIMET DEVICE	PT100		IP21	IP23	IP45
●		<input type="checkbox"/>	<input type="checkbox"/>	<input type="checkbox"/>	<input type="checkbox"/>	●		<input type="checkbox"/>

● = Standard □ = Optional



OVERALL SIZE, STANDARD TYPE

dimensions in mm

FORM B14

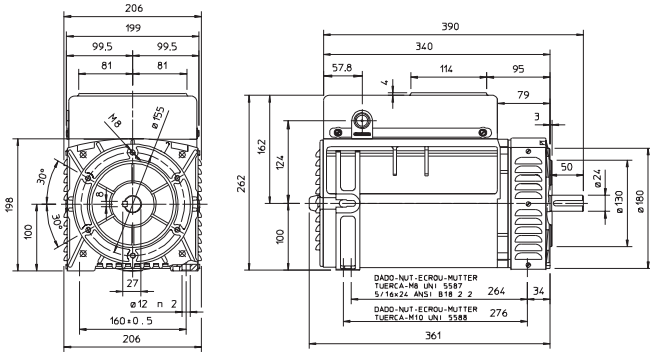

FORM J609a

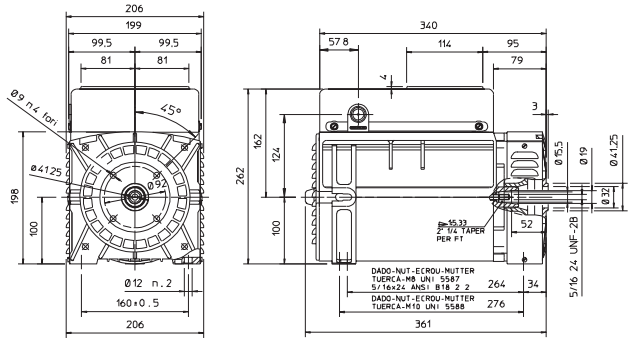

FORM B9/c23

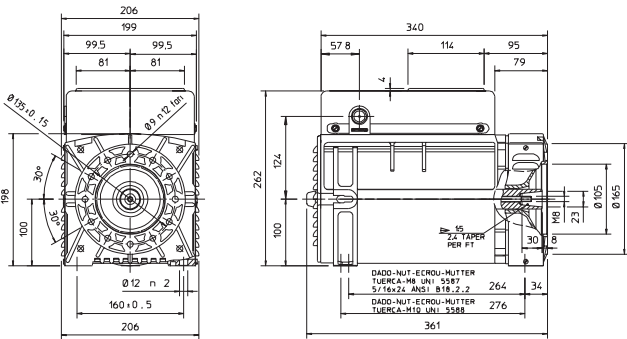

FORM J609b

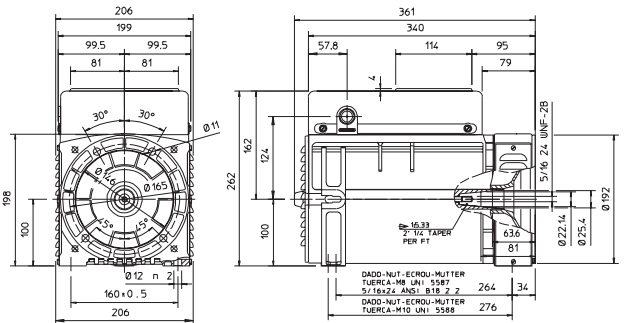

OVERALL SIZE WITH ELECTRIC PANELBOARD TYPE

FORM B14

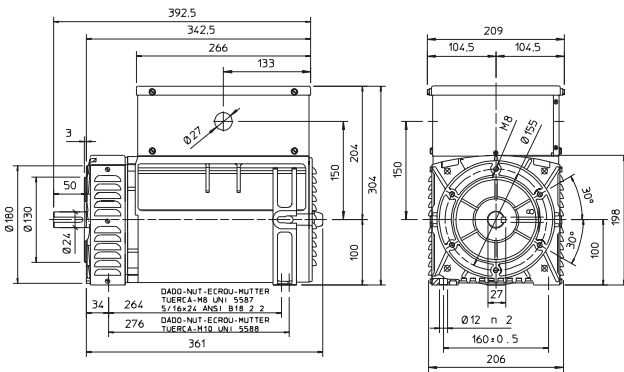

FORM J609a

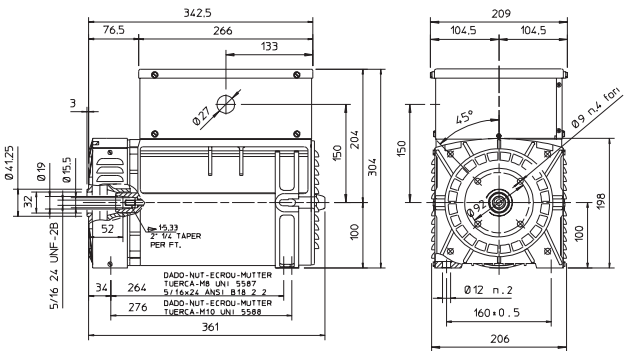

FORM B9/c23

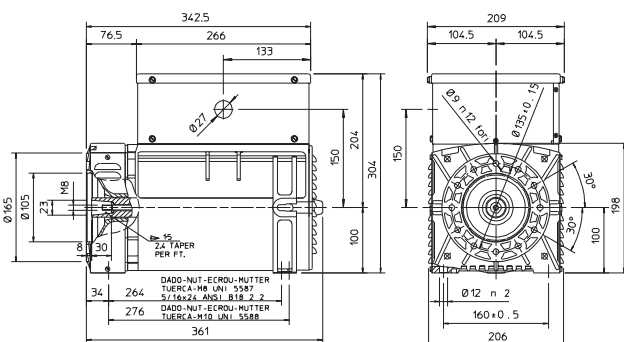

FORM J609b

