



EPW5 D.C.

Zanardi Alternatori s.r.l. Via Dei Laghi, 36077 Altavilla Vicentina (Vicenza) - Italy
 tel. +39 0444 370799 - fax +39 0444 370330 e-mail: info@zanardialternatori.it
 web site: www.zanardialternatori.it

4 POLE

CARATTERISTICHE / CHARACTERISTICS / CARACTERISTIQUES / TECHNISCHE MERKMALE / CARACTERISTICAS

FUNZIONE GENERATORE / OPERATION AS A GENERATOR

TYPE 50 Hz	VELOCITA' SPEED (R.P.M.)	FREQUENZA FREQUENCY (Hz)	POTENZA POWER S1 (Kva)	TENSIONE VOLTAGE (V.)	CORRENTE CURRENT (MAX. S1) (A.)	T.H.D.	COS PHI	GRADO DI PROT. PROTECT. DEGREE (IP)
------------	--------------------------	--------------------------	------------------------	-----------------------	---------------------------------	--------	---------	-------------------------------------

EPW5 500T D.C.	1500	50	10 / 15	230/400	43,4 / 21,6	<10%	0,8	21
----------------	------	----	---------	---------	-------------	------	-----	----

FUNZIONE SALDATRICE / OPERATION AS A WELDER

TYPE 50 Hz	VELOCITA' SPEED (R.P.M.)	CORRENTI DI SALDATURA WELDING CURRENT (Amp.)	TENSIONE INNESCO A.C. STRIKE VOLTAGE (V.)	TENSIONE DI SALDATURA A.C. WELDING VOLTAGE (V.)	FATTORE DI UTILIZZO DUTY CYCLE (X)	ELETTRODI ELECTRODES DIAM. (mm.)	POTENZA DI AZIONAMENTO MAXIMUM POWER (Hp)
------------	--------------------------	--	---	---	------------------------------------	----------------------------------	---

EPW5 500T D.C.	1500	35-500	75	21,5-40	500A.-60%/ 400A.-100%	1,5-8	32
----------------	------	--------	----	---------	-----------------------	-------	----

TIPO TYPE	PESO WEIGHT (Kg.)	VOL. D'ARIA AIR VOL. (m'/min.)	RUMORE NOISE dB (A.)	
			50 Hz.	
			7m.	1m.
EPW5 500 D.C.	220	11,8	60	75

PROTEZIONI E ACCESSORI

PROTECTION AND ACCESSORIES

PROTECTION ET ACCESSOIRES

SCHUTZ UND ZUBEHÖR

PROTECCIONES Y ACCESORIOS

Tutti i generatori – saldatrici sono protetti termicamente in caso di sovraccarichi prolungati e si ripristinano automaticamente.

l'intervento della protezione termica è segnalato da un indicatore luminoso. Il grado di protezione standard è IP 23 (IP21 per EPW5) su specifica richiesta del cliente possono essere forniti gradi di protezione superiori.

All welder generators are equipped with a thermal protection device which intervenes, in case of overload, and self restore it., the thermal invention is signal from luminor spot. The standard degree of protection is IP 23 (IP 21 for EPW5), upon the customer's request, other higher degrees of protection, are available.

Toutes les génératrices de soudage. sont protégées thermiquement en cas de surcharges prolongées. Le retour à la tension nominale s'effectue automatiquement. L'intervention de la protection thermique est signalée par un voyant lumineux. Sur demande spécifique du client, des degrés de protection supérieurs peuvent être fournis.

Alle Schweißgeneratoren, sowohl Wechselstromgeneratoren, sind bei längeren Überbelastungen thermisch geschützt und stellen sich automatisch wieder zurück. wird der Eingriff des Wärmeschutzes außerdem durch eine Kontrolllampe angezeigt. Standard-schutzklasse ist IP 23 (IP 21 EPW5); auf ausdrücklichen Wunsch des kundel sind höhere.

Todos los generadores - soldadoras estan protegidos termicamente en caso de sobrecarga prolongado Y se re-setan automaticamente un indicador luminoso señala la intervencion de la proteccion termica. El grado de proteccion standard es IP 23 (IP 21 para EPW5), bajo pedido especifico del cliente pueden suministrarse grados de proteccion superiores.

DIMENSIONI DI INGOMBRO - OVERALL SIZE - RAUMBEDARF - DIMENSIONES MAXIMAS EXTREMAS

FORMA FORM FORME B3 / B14

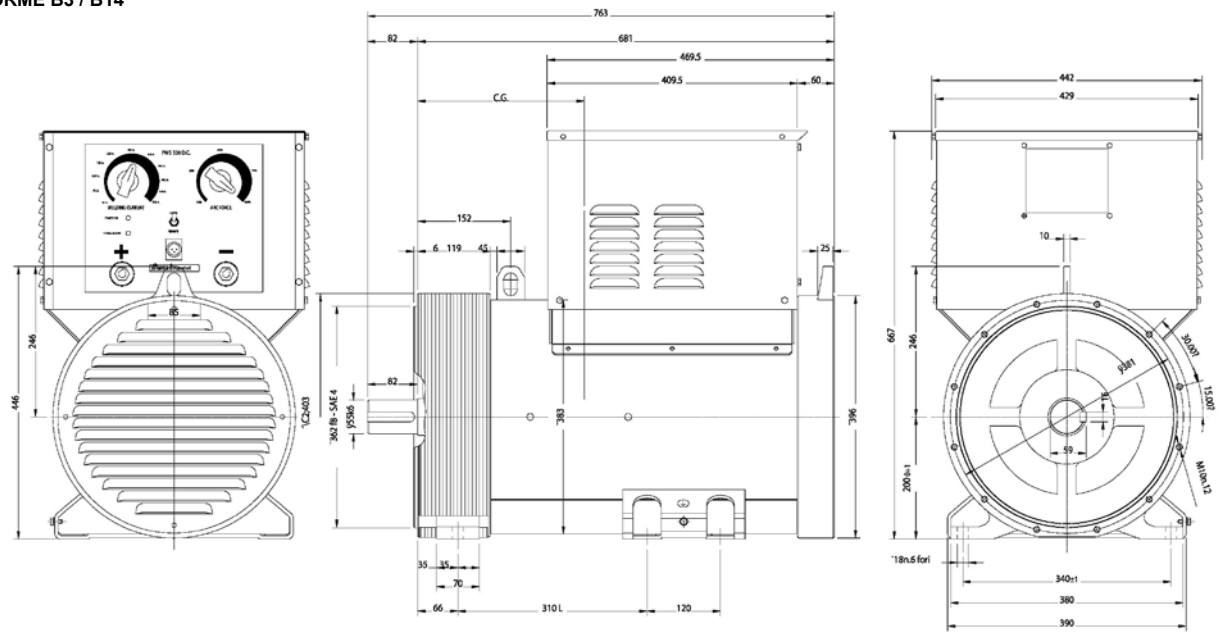

FORMA FORM FORME MD 35

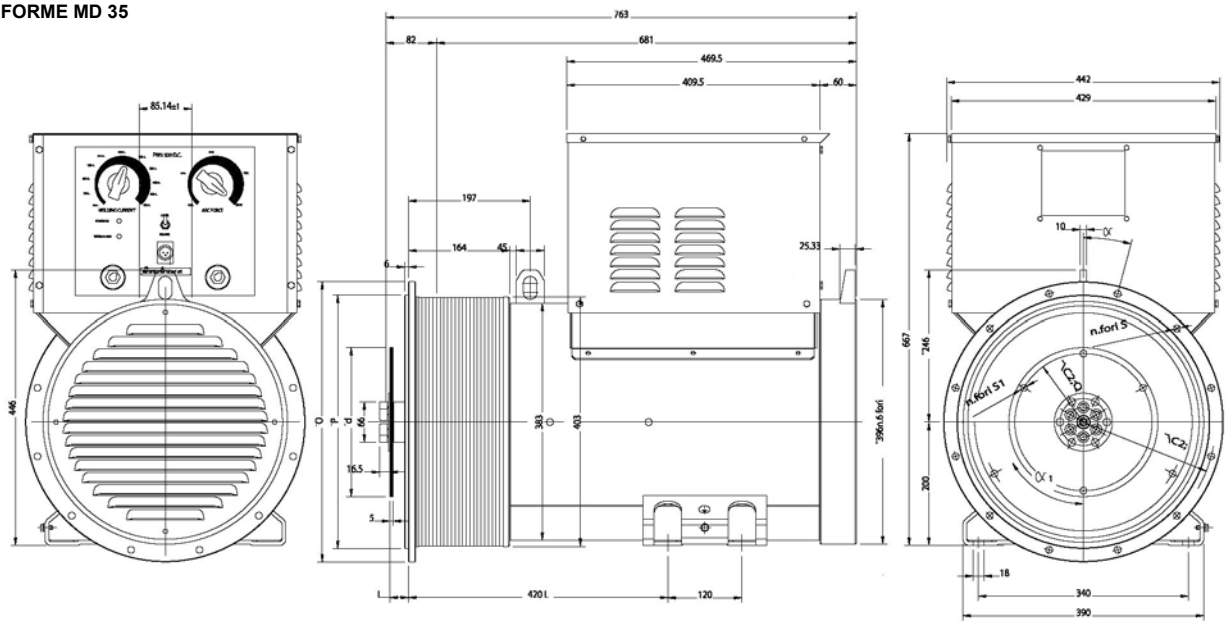

SAE N.	GIUNTI A DISCHI DISC COUPLING DISQUE DE MONOPALIER SCHEIBENKUPPLUNG						
	L	d	Q1	N. FORI	S1	∠1	F
6 1/2	30.2	215,9	200	6	9	60°	7
7 1/2	30.2	241,3	222,25	8	9	45°	7
8	62	263,52	244,47	6	11	60°	2
10	53.8	314,32	295,27	8	11	45°	10
11 1/2	39.6	352,42	333,37	8	11	45°	24

SAE N.	FLANGIA / FLANGE BRIDE / FLANSCH					
	O	P	Q	N. FORI	S	∠
5	356	314,3	333,4	8	11	22°30'
4	403	362	381	12	11	15°
3	451	409,6	428,6	12	11	15°
2	489	447,7	466,7	12	11	15°
1	552	511,2	530,2	12	11	15°

**ELENCO PARTI DI RICAMBIO
LIST OF SPARE PARTS
LISTE DES PIÈCES DÉTACHÉES
ERSATZTEILLISTE LISTA
PARTES DE REPUESTO**

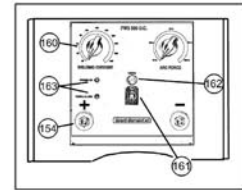
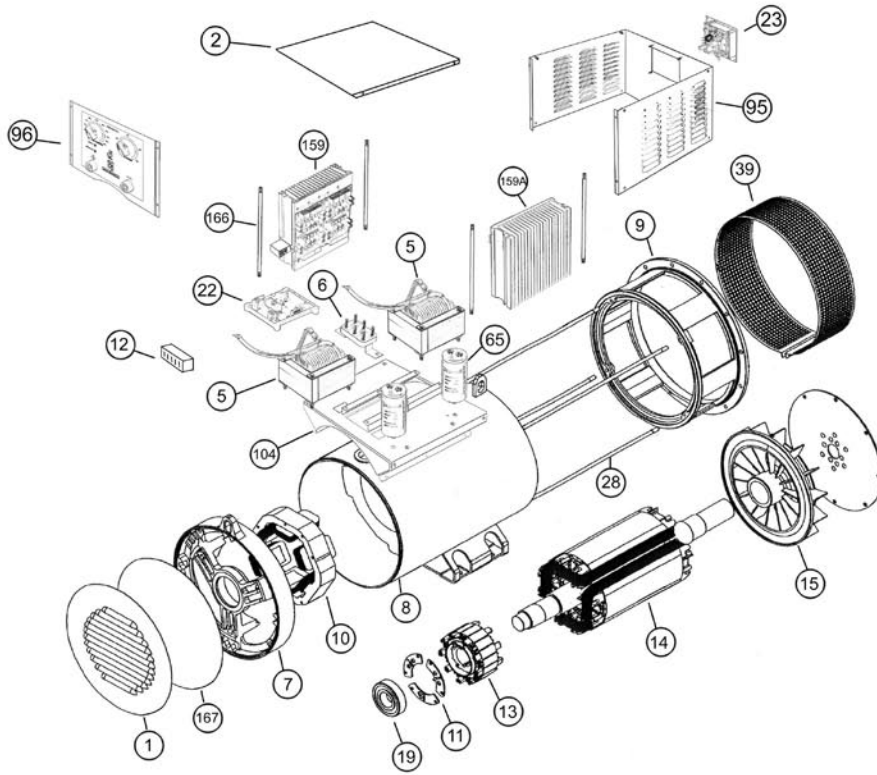

PANNELLO FRONTALE
COMPONENT SIDE PANEL

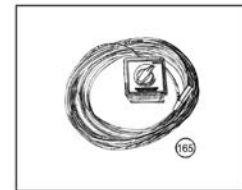

KIT REMOTAGGIO
REMOTE KIT

	ELENCO RICAMBI	LIST OF SPARE PARTS	LISTE DES PIÈCES DÉTACHÉES	ERSATZTEILLISTE LISTA	PARTES DE REPUESTO	CODICE
1	CHIUSURA POSTERIORE PW5	GRID PW5	GRILLE DE FERMETURE PW5	GITTER PW5	REJILLA PW5	9LMCPOSTPW5**
2	COPERCHIO SUPERIORE PW5	TERMINAL BOX LID PW5	COUVERCLE PW5	DECKEL PW5	TAPA PW5	9LMCPSPPW5VER
5	INDUTTANZA PW3/4/5	IMPEDANCE COIL PW3/4/5	REACTANCE PW3/4/5	REAKTANZ PW3/4/5	REACTANCIA PW3/4/5	8ELIDPW4400M5
6	MORSETTIERA DI UTILIZZO PW5	TERMINAL BOARD PW5	PLANCHETTE A BORNES PW5	KLEMMENBRETT PW5	PLACA BORNES TERMINAL PW5	9ELMR01045070
7	COPERCHIO POSTERIORE PW5	BLACK COVER PW5	PALIER ARRIERE PW5	B-LAGER SCHILD PW5	TAPA POSTERIOR PW5	8GHCAPSPW5***
8	CARCASSA CON STATORE PW5	FRAME AND STATOR PW5	CARCASSE AVEC STATOR PW5	GEHÄUSE MIT STATOR PW5	CARCASA CON ESTATOR PW5	8CSPW5500H180
9	COPERCHIO ANTERIORE PW5 B14	DRIVE END BRACKET B14	FLASQUE AVANT B14	VORDERES GEHÄUSE B14	CIERRE ANTERIOR B14	8GHFLANEC32B3
	COPERCHIO ANTERIORE PW5	DRIVE END BRACKET SAE 3/11,5	FLASQUE AVANT SAE 3/11,5	VORDERES GEHÄUSE SAE 3/11,5	CIERRE ANTERIOR SAE 3/11,5	8GHFLANEC32S3
	COPERCHIO ANTERIORE PW5	DRIVE END BRACKET SAE 4/8	FLASQUE AVANT SAE 4/8	VORDERES GEHÄUSE SAE 4/8	CIERRE ANTERIOR SAE 4/8	8GHFLANEC32S4
10	STATORE ECCITATRICE PW4/5	EXCITING STATOR PW4/5	STATOR EXCITATRICE PW4/5	ERREGERSTATOR PW4/5	ESTATOR EXCITATRIZ PW4/5	8STECCECN28*
11	SETTORE PER PONTE ROTANTE	SECTOR FOR ROTATING BRIDGE	SECTEUR POUR PONT TOURNANT	2 DIODEN SEGMENT FUR T30	SECTOR POR PUENTE DIODOS	9ELPDRTT-30**
12	MORSETTIERA AUSILIARIA PW5	AUXILIARY TERMINAL BOARD	BORNES AUXILIAIRES PW5	NEBEN KLEMMBRETT PW5	REGLETA PW5	9ELMRBK006***
13	ROTORE ECCITATRICE PW4/5	EXCITER ARMATURE PW4/5	INDUIT D' EXCITATRICE PW4	ERREGERANGER PW4/5	INDUCTOR EXCITATRIZ PW4/5	8RTAECCECN28*
14	INDUTTORE ROTANTE PW5	ROTATING INDUCTOR PW5	ROUE POLAIRE PW5	ROTOR PW5	INDUCTOR ROTANTE PW5	8RTAPW5H180/4
15	VENTOLA PW5	FAN PW5	VENTILATEUR PW5	LÜFTERRAD PW5	VENTILADOR PW5	9ALVNTECN31**
17	CUSCINETTO ANTERIORE PW5 6312	FRONT BEARING PW5	ROULEMENT AVANT PW5	VORDERES LAGER PW5	COJINETE DELANTERO PW5	9MNC5013122RS
19	CUSCINETTO POSTERIORE PW5	REAR BEARING PW5	ROULEMENT ARRIERE PW5	HINTER LAGER PW5	COJINETE POSTERIOR PW5	9MNC5013092RS
22	SCHEDA REG. SALDATURA PW3/4/5	ELECTRONIC WELDER	REGULATEUR ELECTRONIQUE	ELEKTRONISCHER REGEL	REGULADOR ELECTR. SALDADORA	9ELSCHPW3/4/5
23	REGOLATORE ELETTRONICO	ELECTRONIC REGULATOR	REGULATEUR ELECTRONIQUE	ELEKTRONISCHER REGLER	REGULADOR ELECTRONICO	8ELRGEVR01049
28	TIRANTI COPERCHI PW5	COVER STAY BOLT PW5	TIGE DE FLASQUE PW5	STEBBOLZEN PW5	TIRANTE DE LA TAPA PW5	9ACTRECO32L**
39	RETINA DI PROTEZIONE PW5 B14	PROTECTION SCREEN PW5 B14	GRILLE DE PROTECTION PW5 B14	ABLUF TGITTER PW5 B14	REJILLA PROTECCION PW5 B14	9FERTPRTPW5B3
	RETINA DI PROTEZIONE PW5 MD-35	PROTECTION SCREEN PW5	GRILLE DE PROTECTION PW5 MD-35	ABLUF TGITTER PW5 MD-35	REJILLA PROTECCION PW5 MD-35	9FERTPRTPW5MD
60	DISCHI SAE	DISCPLATES	DISQUES	KUPPLUNGSSCHEIBEN SAE	DISCOS SAE	***
65	CONDENSATORE ELETTRIC.	CAPACITOR PW3/4/5	CONDENSATEUR PW3/4/5	KONDENSATOR PW3/4/5	CONDENSADOR PW3/4/5	9ELCNDL100V
95	PANNELLO LATO ASPIR. PW5	SUCTION SIDE PANEL PW5	PANNEAU PW5	TAFEL.....PW5	PANEL LATO ASPIR. PW5	8ALPANNSTRVER
96	PANNELLO LATO COMPONENTI	COMPONENT SIDE PANEL PW5	PANNEAU COMPOSANTS PW5	KOMPONENTEN TAFEL PW5	PANEL LATO COMPONENTES PW5	8ALPANNFRVER
104	MENSOLA PORTACOMPONENTI	COMPONENT-CARRYING PANEL	PANNEAU SUPPORT COMPOSANT	KOMPONENTENBLECHTAFEL	PANEL PORTA COMPONENTES	8LMMNPSPW5VER
159	CHOPPER PW5	CHOPPER PW5	CHOPPER PW5	CHOPPER PW5	CHOPPER PW5	9ELRDCHP600A
	RADDRIZZATORE CHOPPER PW5	CHOPPER PW5	CHOPPER PW5	CHOPPER PW5	CHOPPER PW5	***
165	KIT REMOTAGGIO	REMOTE KIT	REMOTE KIT	VERBINDUNG KIT	KIT REMOTO	AKITRMPW3/4/5
166	TIRANTE CHOPPER	CHOPPER STAY BOLT	TIGE DE CHOPPER	STEBBOLZEN CHOPPER	TIRANTE CHOPPER	9FETR08215393

	PANNELLO	PANEL	PANNEAU	TAFEL	PANEL	CODICE
154	PRESE DI SALDATURA PW3/4	WELDING SOCKET PW3/4	BORNE DE SOUDAGE PW3/4	SCHWEIß-STECKDOSE PW3/4	TOMA DE SOLDADURA PW3/4	9ELPRFS400***
154	PRESE DI SALDATURA PW5	WELDING SOCKET PW5	BORNE DE SOUDAGE PW5	SCHWEIß-STECKDOSE PW5	TOMA DE SOLDADURA PW5	9ELPRFD600***
160	POTENZIOMETRO	POTENTIOMETER	POTENTIOMETRE	POTENTIOMETER	POTENCIOMETRO	9ELPTZ2W10K2N
161	CONNETTORE REMOTAGGIO	REMOTE CONNECTOR	REMOTE CONNECTEUR	VERBINDUNGSSTÜCK	CONECTOR REMOTO	9ELCNTPNL3P**
162	SPIA LUX ROSSA	RED LIGHT	LUMIERE ROUGE	ROTE KONTROLLEUCHE	ALARMA LUZ ROJA	9ELLRXS220***
163	LED ROSSO E VERDE	RED GREEN LED	LED LUMIERE VERTE	ROTE UND GRÜNE LED	LED ROJO Y VERDE	9ELINDLEDVR(RD)MN

Nella richiesta di parti di ricambio specificare il tipo e il codice dell'alternatore / when requesting spare parts always indicate the alternator's type and code
 Pour toute demande de pièces détachées, prière de mentionner le type et le code des alternateurs / Wechselstromgeneratoren angeben / En cada pedido de piezas de recambio especificar siempre el tipo y el código del alternador