



EPW3 D.C.

Zanardi Alternatori s.r.l. Via Dei Laghi, 36077 Altavilla Vicentina (Vicenza) - Italy
 tel. +39 0444 370799 - fax +39 0444 370330 e-mail: info@zanardialternatori.it
 web site: www.zanardialternatori.it

2 POLE

CARATTERISTICHE / CHARACTERISTICS / CARACTERISTIQUES / TECHNISCHE MERKMALE / CARACTERISTICAS

FUNZIONE GENERATORE / OPERATION AS A GENERATOR

TYPE 50 Hz	VELOCITA' SPEED (R.P.M.)	FREQUENZA FREQUENCY (Hz)	POTENZA POWER S1 (Kva)	TENSIONE VOLTAGE (V.)	CORRENTE CURRENT (MAX. S1) (A.)	T.H.D.	COS PHI	GRADO DI PROT. PROTECT. DEGREE (IP)
EPW3 300T D.C.	3000	50	4/10	230/400	17,3 / 14,4	<6%	0,8	23

FUNZIONE SALDATRICE / OPERATION AS A WELDER

TYPE 50 Hz	VELOCITA' SPEED (R.P.M.)	CORRENTI DI SALDATURA WELDING CURRENT (Amp.)	TENSIONE INNESCO A.C. STRIKE VOLTAGE (V.)	TENSIONE DI SALDATURA A.C. WELDING VOLTAGE (V.)	FATTORE DI UTILIZZO DUTY CYCLE (X)	ELETTRODI ELECTRODES DIAM. (mm.)	POTENZA DI AZIONAMENTO MAXIMUM POWER (Hp)
EPW3 300T D.C.	3000	35-300	70	21,5-32	300A.-35%/ 240A.-60%	1,5-6	20

TIPO TYPE	PESO WEIGHT (Kg.)	VOL. D'ARIA AIR VOL. (m'/min.)		RUMORE NOISE dB (A.)	
		50 Hz	60 Hz	50 Hz.	
				7m.	1m.
EPW3 300 D.C.	105	6	7,2	85	70

PROTEZIONI E ACCESSORI

PROTECTION AND ACCESSORIES

PROTECTION ET ACCESSOIRES

SCHUTZ UND ZUBEHÖR

PROTECCIONES Y ACCESORIOS

Tutti i generatori – saldatrici sono protetti termicamente in caso di sovraccarichi prolungati e si ripristinano automaticamente. l'intervento della protezione termica è segnalato da un indicatore luminoso. Il grado di protezione standard è IP 23 (IP21 per EPW5) su specifica richiesta del cliente possono essere forniti gradi di protezione superiori.

All welder generators are equipped with a thermal protection device which intervenes, in case of overload, and self restore it., the thermal invention is signal from luminor spot. The standard degree of protection is IP 23 (IP 21 for EPW5), upon the customer's request, other higher degrees of protection, are available.

Toutes les génératrices de soudage. sont protégées thermiquement en cas de surcharges prolongées. Le retour à la tension nominale s'effectue automatiquement. L'intervention de la protection thermique est signalée par un voyant lumineux. Sur demande spécifique du client, des degrés de protection supérieurs peuvent être fournis.

Alle Schweißgeneratoren, sowohl Wechselstromgeneratoren, sind bei längeren Überbelastungen thermisch geschützt und stellen sich automatisch wieder zurück. wird der Eingriff des Wärmeschutzes außerdem durch eine Kontrolllampe angezeigt. Standard-schutzklasse ist IP 23 (IP 21 EPW5); auf ausdrücklichen Wunsch des kundel sind höhere.

Todos los generadores - soldadoras estan protegidos termicamente en caso de sobrecarga prolongado Y se re-setan automaticamente un indicador luminoso señala la intervencion de la proteccion termica. El grado de proteccion standard es IP 23 (IP 21 para EPW5), bajo pedido especifico del cliente pueden suministrarse grados de proteccion superiores.

SCHEMA ELETTRICO - WIRING DIAGRAM - SCHEMA ELECTRIQUE - SCHALTPLAN - ESQUEMA ELECTRICO

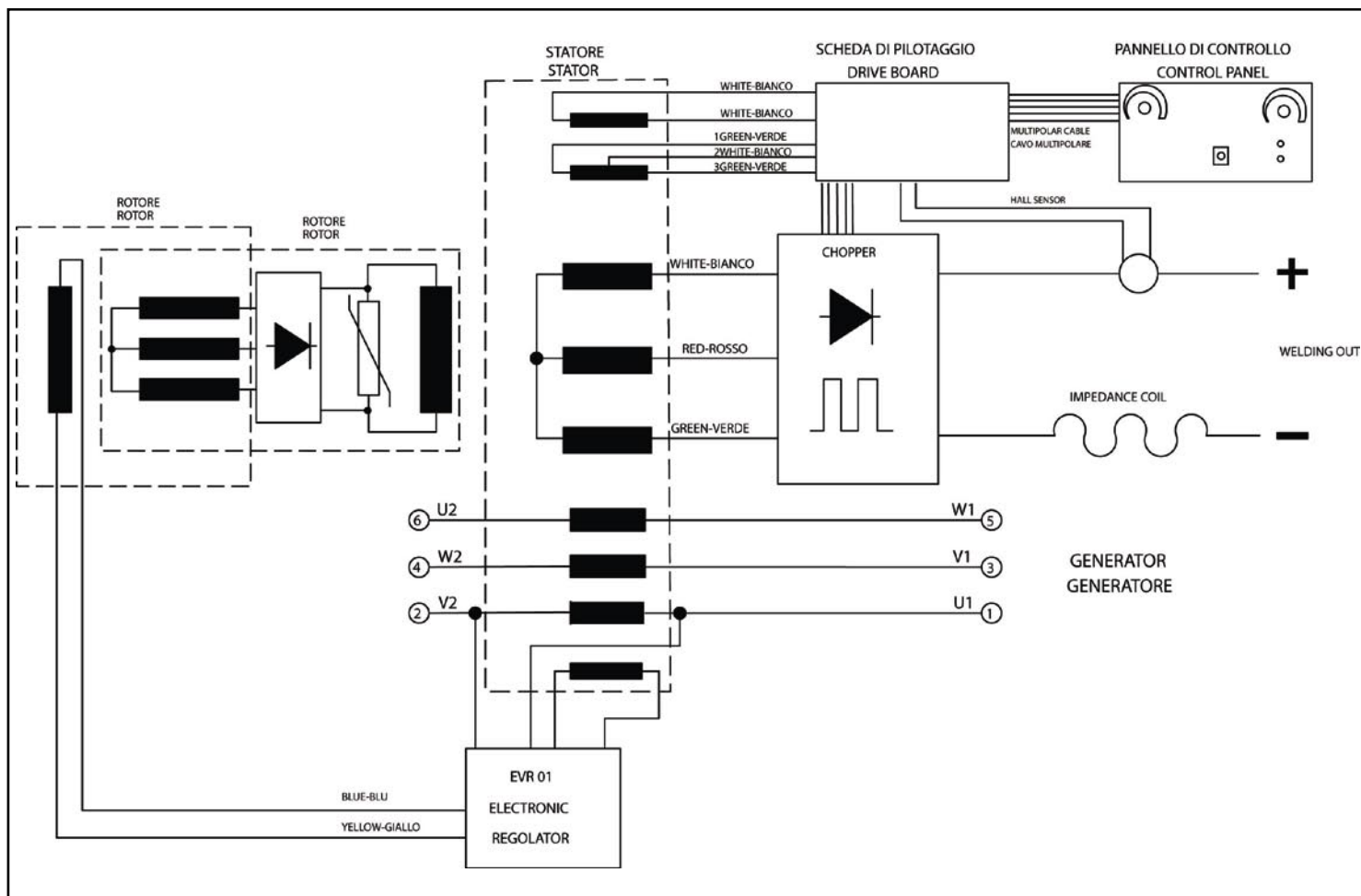

DIMENSIONI DI INGOMBRO - OVERALL SIZE - RAUMBEDARF - DIMENSIONES MAXIMAS EXTREMAS

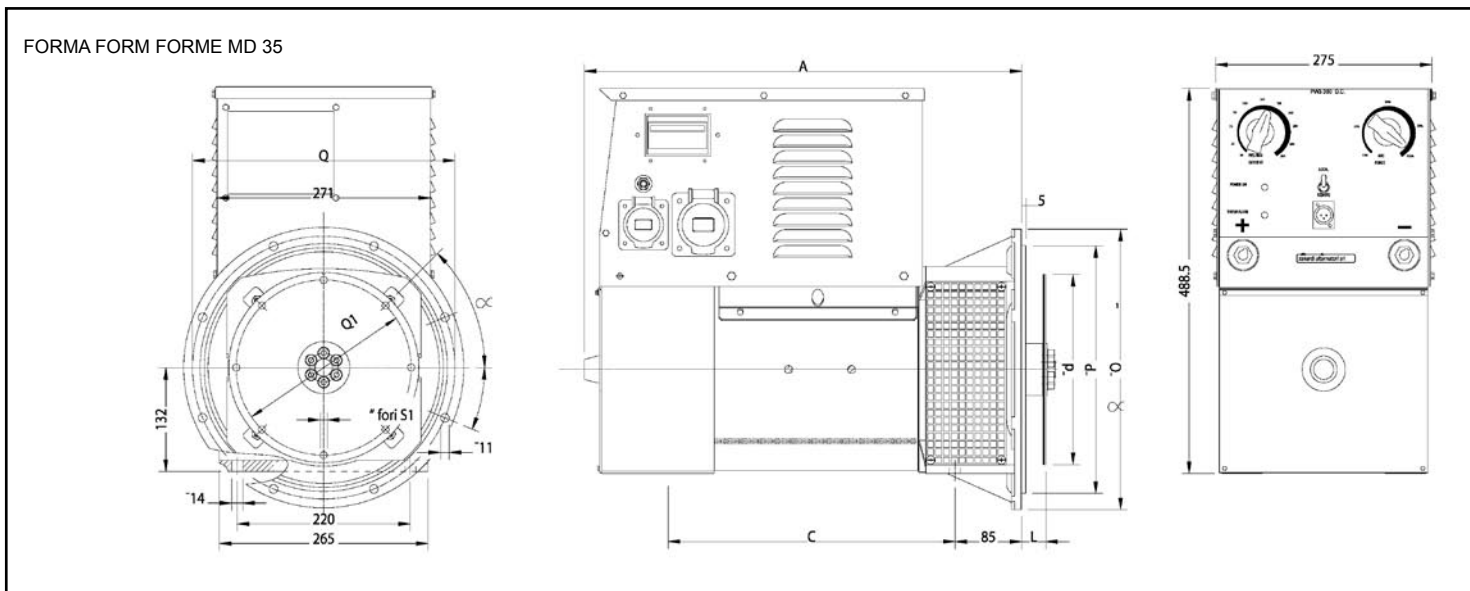

FORMA FORM FORME		A	B	C	E	F
B14	S	511	454	301	*	*
	L	581	524	371	*	*
B9	S	454	*	301	*	*
	L	524	*	371	*	*
J609b	S	454	*	301	146,1	165,1
					163,6	196,8
	L	524	*	371	177,8	196,8
MD35	S	491	*	301	*	*
	L	561	*	371	*	*

FLANGIE - FLANGE - BRIDE FLANSCHÉ - BRIDAS					
SAEN.	O	P	Q	N?fori	∞
6	308	266,7	285,75	8	22730'
5	356	314,3	333,4	8	22730'
4	403	362	381	12	157
3	451	409,6	428,6	12	157

GIUNTO A DISCO - COUPLING DISC PLATEX DISQUE DE MONOPALIER - SCHEIBENKUPPLUNG JUNTAS A DISCOS						
SAEN.	L	d	Q1	N?fori	S1	∞ 1
6?	30,2	215,9	200	9	6	607
7?	30,2	241,3	222,25	9	8	457
8	62	263,52	244,47	11	6	607
10	53,8	314,52	295,27	11	8	457
11?	39,6	352,42	333,37	11	8	457

FORMA FORM FORME B3 / B14

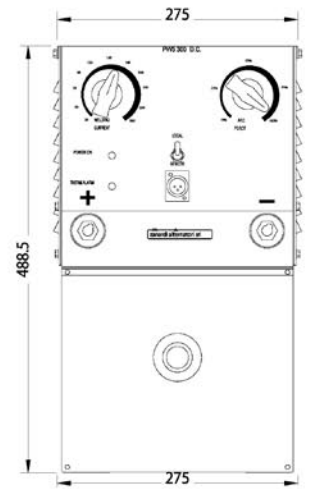
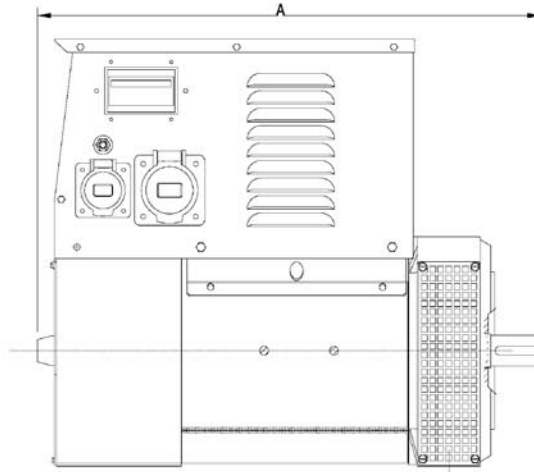
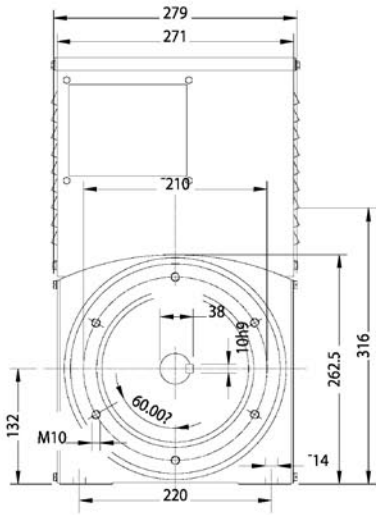

FORMA FORM FORME B3 / B9

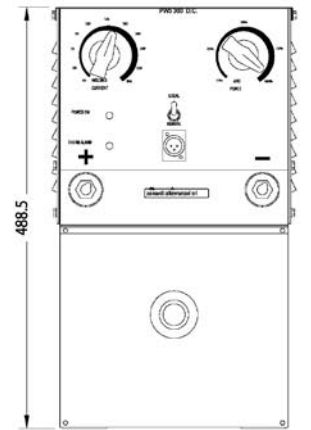
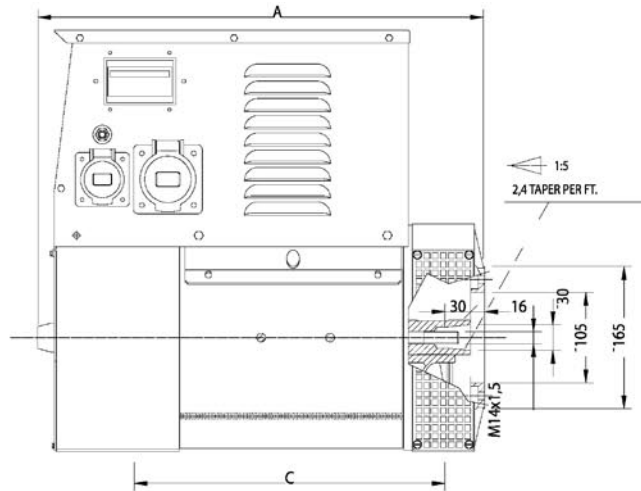
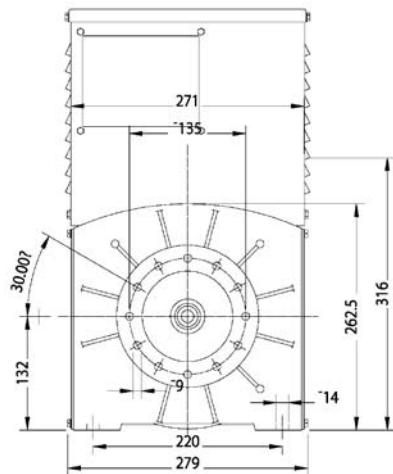

FORMA FORM FORME J 609 B

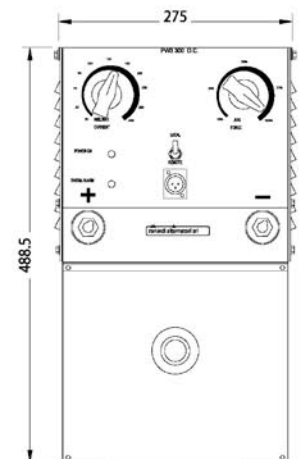
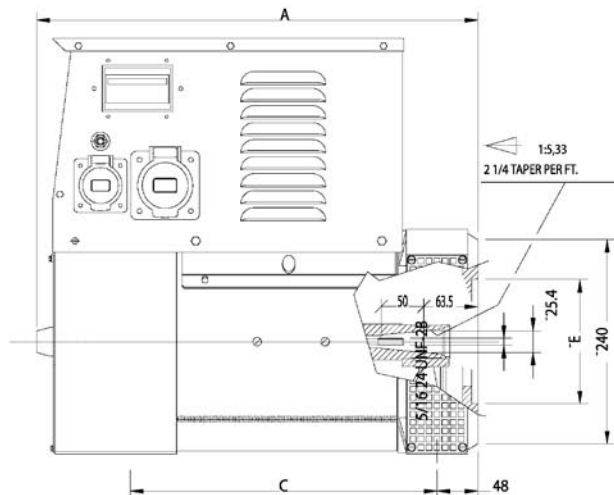
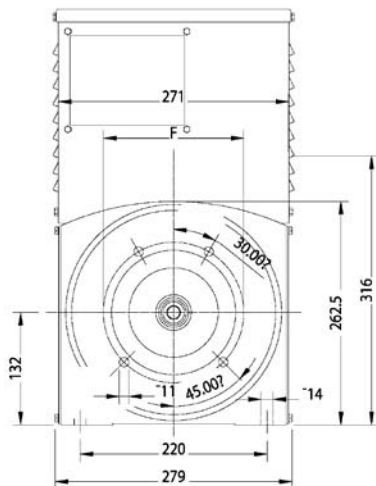

**ELENCO PARTI DI RICAMBIO
LIST OF SPARE PARTS
LISTE DES PIECES DETACHEES
ERSATZTEILLISTE LISTA
PARTES DE REPUESTO**

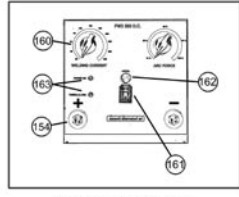
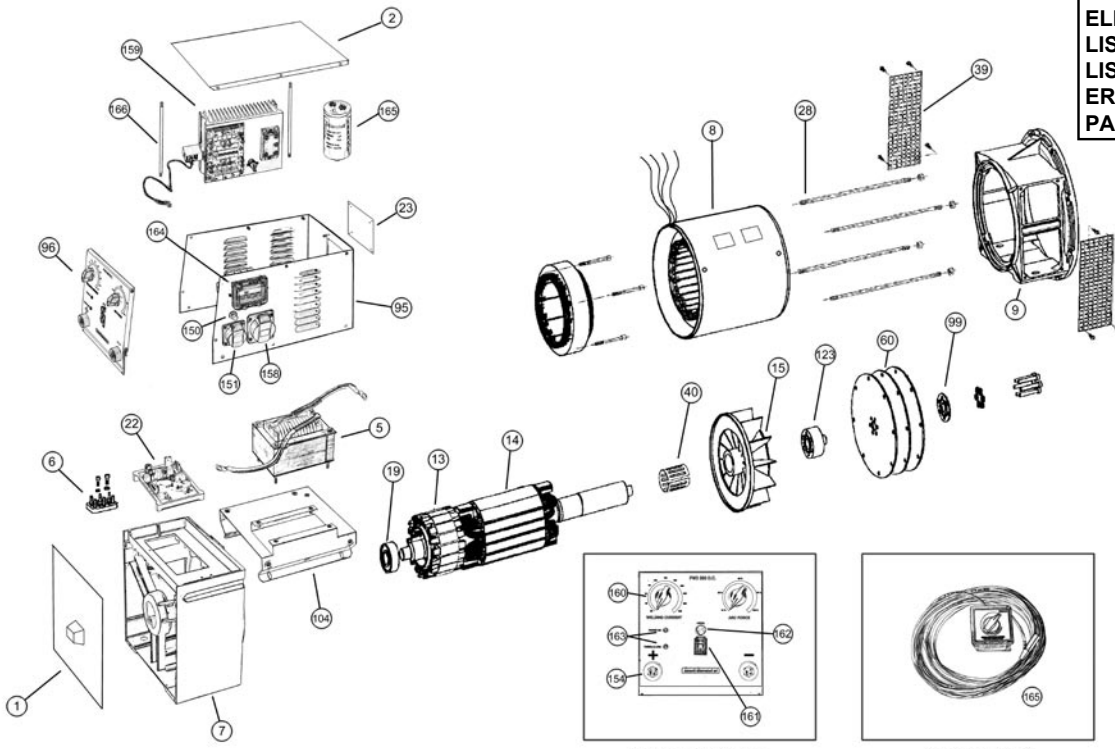

PANNELLO FRONTALE
COMPONENT SIDE PANEL

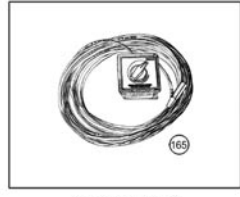

KIT REMOTAGGIO
REMOTE KIT

	ELENCO RICAMBI	LIST OF SPAIR PARTS	LISTE DES PIECES DETACHEES	ERSATZTEILLISTE LISTA	PARTES DE REPUESTO	CODICE
1	CHIUSURA POSTERIORE PW3	GRID PW3	GRILLE DE FERMETURE PW3	GITTER PW3	REJLLA PW3	8ALPANNFRBPW3
2	COPERCHIO SUPERIORE PW3	TERMINAL BOX LID PW3	COUVERCLE PW3	DECKEL PW3	TAPA PW3	9LMCSPWPW3VER
5	INDUTTANZA PW3/4/5	IMPEDANCE COIL PW3/4/5	REACTANCE PW3/4/5	REAKTANZ PW3/4/5	REACTANCIA PW3/4/5	8ELIDPW4400M5
6	MORSETTIERA DI UTILIZZO PW3	TERMINAL BOARD PW3	PLANCHETTE A BORNES PW3	KLEMMENBRETT PW3	PLACA BORNES TERMINAL PW3	9ELMR01036056
7	COPERCHIO POSTERIORE PW3	BLACK COVER PW3	PALIER ARRIERE PW3	B-LAGER SCHILD PW3	TAPA POSTERIOR PW3	8ALCAPSPW3**
8	CARCASSA CON STATORE PW3	FRAME AND STATOR PW3	CARCASSE AVEC STATOR PW3	GEHAÜSE MIT STATOR PW3	CARCASA CON ESTATOR PW3	8CSPW3300H160
9	COPERCHIO ANTERIORE PW3 CBS	DRIVE END BRACKET CBS	FLASQUE AVANT CBS	VORDERES GEHAÜSE CBS	CIERRE ANTERIOR CBS	8ALFLANEPW3BS
10	STATORE ECCITATRICE PW3	EXCITING STATOR PW3	STATOR EXCITATRICE PW3	ERREGERSTATOR PW3	ESTATOR EXCITATRIZ PW3	8STECCECO3PW3
	STATORE ECCITATRICE PW4/5	EXCITING STATOR PW4/5	STATOR EXCITATRICE PW4/5	ERREGERSTATOR PW4/5	ESTATOR EXCITATRIZ PW4/5	8STECCECN28*
11	SETTORE PER PONTE ROTANTE T30	SECTOR FOR ROTATING BRIDGE T30	SECTEUR POUR PONT TOURNANT T30	2 DIODEN SEGMENT FÜR T30	SECTOR POR PUENTE DIODOS GIRA-	9ELPDRTT-30**
12	MORSETTIERA AUSILIARIA PW3	AUXILIARY TERMINAL BOARD PW3	BORNES AUXILIAIRES PW3	NEBEN KLEMMBRETT PW3	REGLETA PW3	9ELMROK433/06
13	ROTORE ECCITATRICE PW3	EXCITER ARMATURE PW3	INDUIT D'EXCITATRICE PW3	ERREGERANGER PW3	INDUCTOR EXCITATRIZ PW3	8RTECCPW3300*
	ROTORE ECCITATRICE PW4/5	EXCITER ARMATURE PW4/5	INDUIT D'EXCITATRICE PW4	ERREGERANGER PW4/5	INDUCTOR EXCITATRIZ PW4/5	8RTAECCECN28*
14	INDUTTORE ROTANTE PW3	ROTATING INDUCTOR PW3	ROUE POLAIRE PW3	ROTOR PW3	INDUCTOR ROTANTE PW3	8RTAPW3H160BS
15	VENTOLA PW3	FAN PW3	VENTILATEUR PW3	LÜFTERRAD PW3	VENTILADOR PW3	9ALVNTD40PW3B
17	CUSCINETTO ANTERIORE PW3	FRONT BEARING PW3	ROULEMENT AVANT PW3	VORDERES LAGER PW3	COJINETE DELANTERO PW3	9MNC5013082RS
19	CUSCINETTO POSTERIORE PW3 6305	REAR BEARING PW3	ROULEMENT ARRIERE PW3	HINTER LAGER PW3	COJINETE POSTERIOR PW3	9MNC501305C3*
22	SCHEDA REG. SALDATURA PW3/4/5	ELECTRONIC WELDER REGULATOR	REGULATEUR ELECTRONIQUE SOUDAGE	ELEKTRONISCHER REGEL SCHWEIS.	REGULADOR ELECTR. SOLDADORA	9ELSCHPW3/4/5
23	REGOLATORE ELETTRONICO PW3/4/5	ELECTRONIC REGULATOR PW3/4/5	REGULATEUR ELECTRONIQUE PW3/4/5	ELEKTRONISCHER REGLER PW3/4/5	REGULADOR ELECTRONICO PW3/4/5	8ELRGEVR01049
28	TIRANTI COPERCHI PW3	COVER STAY BOLT PW3	TIGE DE FLASQUE PW3	STEBBOLZEN PW3	TIRANTE DE LA TAPA PW3	9ACTRECO3L***
39	RETINA DI PROTEZIONE PW3	PROTECTION SCREEN PW3	GRILLE DE PROTECTION PW3	ABLÜFTGITTER PW3	REJILLA PROTECCION PW3	***
65	CONDENSATORE ELETTRIC. PW3/4/5	CAPACITOR PW3/4/5	CONDENSATEUR PW3/4/5	KONDENSATOR PW3/4/5	CONDENSADOR PW3/4/5	9ELCNDLT100V
96	PANNELLO LATO COMPONENTI PW3	COMPONENT SIDE PANEL PW3	PANNEAU COMPOSANTS PW3	KOMPONENTEN TAFEL PW3	PANEL LADO COMPONENTES PW3	8ALPANNFRAPW3
104	MENSOLA PORTACOMPONENTI PW3	COMPONENT-CARRYING PANEL PW3	PANNEAU SUPPORT COMPOSANT PW3	KOMPONENTENBLECHTAFEL PW3	PANEL PORTA COMPONENTES PW3	8LMMNPPW3VER
150	DISGIUNTORE TERMICO	THERMIC	DISJONCTEUR THERMIQUE	THERMISCH	INTERRUPTOR TERMICO	9ELDS01015***
151	PRESA MONOFASE	SINGLE PHASE SOCKET	PRISE MONOPHASE E	EINPHASIGE STECKDOSE	TOMA MONOFASICA	9ELPR16200***
158	PRESA TRIFASE	THREE PHASE SOCKETS	PRISE TRIPHASE E	DREIPHASIGE STECKDOSE	TOMA TRIFASICA	9ELPR16311***
159	CHOPPER PER PW3	CHOPPER PW3	CHOPPER PW3	CHOPPER PW3	CHOPPER PW3	9ELRDCHOP300A
164	INTERRUTTORE AUTOMATICO	MAGNETO THERMAL DEVICE	INTERRUPTEUR AUTOMATIQUE	AUTOMATISCHER UNTERBRECHER	INTERRUPTOR AUTOMATICO	9ELINAU416***
165	KIT REMOTAGGIO	REMOTE KIT	REMOTE KIT	VERBINDUNG KIT	KIT REMOTO	AKITRMPW3/4/5
166	TIRANTE CHOPPER	CHOPPER STAY BOLT	TIGE DE CHOPPER	STEBBOLZEN CHOPPER	TIRANTE CHOPPER	9FETR08215393

	PANNELLO	PANEL	PANNEAU	TAFEL	PANEL	CODICE
154	PRESE DI SALDATURA PW3/4	WELDING SOCKET PW3/4	BORNE DE SOUDAGE PW3/4	SCHWEIß-STECKDOSE PW3/4	TOMA DE SOLDADURA PW3/4	9ELPRFS400***
160	POTENZIOMETRO	POTENTIOMETER	POTENTIOMETRE	POTENTIOMETER	POTENCIOMETRO	9ELPTZ2W10K2N
161	CONNETTORE REMOTAGGIO	REMOTE CONNECTOR	REMOTE CONNECTEUR	VERBINDUNGSSTÜCK	CONECTOR REMOTO	9ELCNTPNL3P**
162	SPIA LUX ROSSA	RED LIGHT	LUMIERE ROUGE	ROTE KONTROLLEUCHTE	ALARMA LUZ ROJA	9ELLRXS220***
163	LED ROSSO E VERDE	RED GREEN LED	LED LUMIERE ROUGE	ROTE UND GRÜNE LED	LED ROJO Y VERDE	9ELINDLEDVR(RD)MN

Nella richiesta di parti di ricambio specificare il tipo e il codice dell'alternatore / when requesting spare parts always indicate the alternator's type and code
 Pour toute demande de pieces detachees, priere de mentionner le type et le code de l'alternateur
 Bei ersatzteilbestellung bitte immer die teilbenennung den typ und den code des wechselstromgenerators angeben
 En cada pedido de piezas de recambio especificar siempre el tipo y el codigo del alternador